

Contact thermometer

Bimetal- or Gas actuated thermometer

- Inductive contacts
- Sliding contacts
- Snap action contact
- Class 1 acc. to DIN EN 13190
- Optional with liquid damping

Description

Contact thermometers are suitable for controlling or regulating process sequences with the aid of the process temperature. The contacts open or close electrical circuits in relation to the position of the pointer on the thermometer. With change over contacts one contact will be closed, another one opened, when reaching the switching temperature.

Sliding contacts operate with physical contact. These contacts can be used in applications without vibrations and for switching small capacities. Contact thermometers with sliding contacts are not available with liquid damping.

Inductive contacts operate without physical contact and with very little effect on the mechanical measuring system while having an unlimited service life. A control unit is always needed to operate these contacts. Thermometers with electrical alarm contacts can be used in potentially explosive atmospheres, provided that the appropriate regulations are complied with.

Snap action contacts can only be used with gas actuated thermometers. These contacts are less sensitive to vibrations and can be used under raw ambient conditions.

If the electrical switching capacities are exceeded or not reached (see DE 1231), a relay (see DE 1230) is to be used to provide an appropriate current rating.

If large vibrations occur in the installation it is recommended to use the liquid filled type. The liquid causes the necessary damping and at the same time a good lubrication of movable parts. Liquid damping is available for inductive- and snap action contacts.

In conjunction with a corresponding thermowell, these thermometers can also be used with aggressive media or high process-pressures (see DE 1060).



Features

- Short response time
- Nominal sizes acc. to DIN EN 13190
- Up to 3 contacts
- Suitable for PLC inputs
- Customized versions available

Measuring ranges

- Gas actuated thermometer: -80°C...700°C
- Bimetal thermometer: -70°C...600°C

Options

- Models with turnable and rotateable connection
- Liquid damping
 - for bimetal thermometer:
 - with inductive contacts up to 250°C
 - for gas actuated thermometer:
 - with snap action contacts or inductive contacts up to 700°C

Applications

- Chemical and petrochemical industry
- Machine construction
- Process engineering
- Food industry

Models: TM810, TM820, TM830, TM840, TM850, TM860, TM870

Technical Data

Nominal size (mm)

100 und 160

Measuring principle

Bimetal system

or

Gas actuated (inert gas filling, physiologically harmless)

Accuracy

Class 1 acc.to DIN EN 13190

Range of use

Short time (<24h): Scale range

Constant load: Measuring range (DIN EN13190)

Contact type

Bimetal: Sliding- or inductive contact

Gas actuated: Snap action-, sliding- or inductive contact

Contact function

Normally open, normally closed, change over (not with inductive contact)

Number of contacts

3 as Normally Open or Normally Closed

2 as Change over contacts

Position of electrical connection

Bimetal: right

Gas actuated: left

Process connection

- back mount

- lower mount

- turnable/rotateable

- with capillary

Stem material

Stainless steel 1.4571

Stem diameter

6, 8, 10, 12 mm

Ingress protection

IP 65 acc. to EN60529

Max. pressure at stem

Max. 25 bar statical

depending on medium, medium temperature, flow velocity and installation length

Window

Bimetal: Flat instrument glass

Gas actuated: Laminated safety glass

Dial

White aluminium, black marking and scale

Pointer

Aluminium black

Scale range, Measuring range, Scale gradations, Limits of error (acc. to EN 13190)

Scale range	Measuring range	Scale gradations	Limits of error
-30 ... +50°C	-20 ... +40°C	1°C	±1°C
-20 ... +60°C	-10 ... +50°C	1°C	±1°C
0 ... +60°C	+10 ... +50°C	1°C	±1°C
0 ... +100°C	+10 ... +90°C	1°C	±1°C
0 ... +120°C	+10 ... +110°C	2°C	±2°C
0 ... +160°C	+20 ... +140°C	2°C	±2°C
0 ... +200°C	+20 ... +180°C	2°C	±2°C
0 ... +250°C	+30 ... +220°C	5°C	±2,5°C
0 ... +300°C	+30 ... +270°C	5°C	±5°C
0 ... +400°C	+50 ... +350°C	5°C	±5°C
0 ... +500°C	+50 ... +450°C	5°C	±5°C
0 ... +600°C	+100 ... 500°C	10°C	±10°C
0 ... +700°C	+100 ... +600°C	10°C	±10°C

Design of connection

	Male thread	Plain stem	Male nut	Union nut	Compression fitting														
Stem-length l_1	63 mm 100 mm 160 mm 200 mm 250 mm	140 mm 200 mm 240 mm 290 mm	80 mm 140 mm 180 mm 230 mm	89 mm 126 mm 186 mm 226 mm 276 mm	variable min. insertion length $l_{min} = 60$ mm length $l \geq l_1 + 35$ mm														
Dimensions																			
Thread and dimensions [mm]		SW	d4	i			SW	d4	i										
	G 1/2	27	32	14	G 1/2	27	20	G 1/2	27	26	14								
	G 3/4	32	26	16				G 3/4	32	32	16								
	1/2 NPT	22	-	19				M24x1,5	32	13,5	M18x1,5	24	23	12					
	3/4 NPT	30	-	20							1/2 NPT	22	-	19					
	not possible with TM830, TM860 and TM870																		at model TM870 the compression fitting can be - sliding on stem - sliding on capillary

Model overview

TM810	TM820	TM830	TM840	TM850	TM860	TM870
Bimetal			Gas actuated			
Back mount	Lower mount	Turnable/rotateable	Back mount	Lower mount	Turnable/rotateable	With capillary

Dimensions: Model TM810/TM840

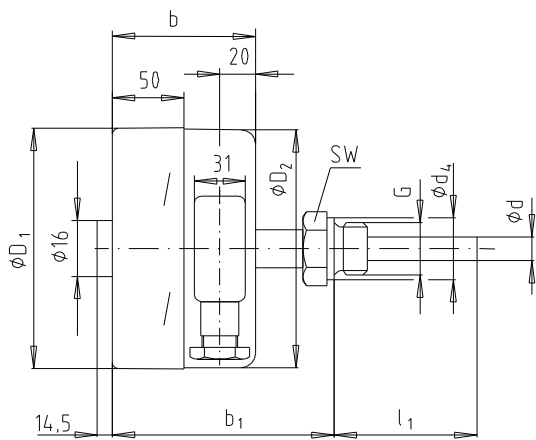

Dimensions: Model TM820/TM850

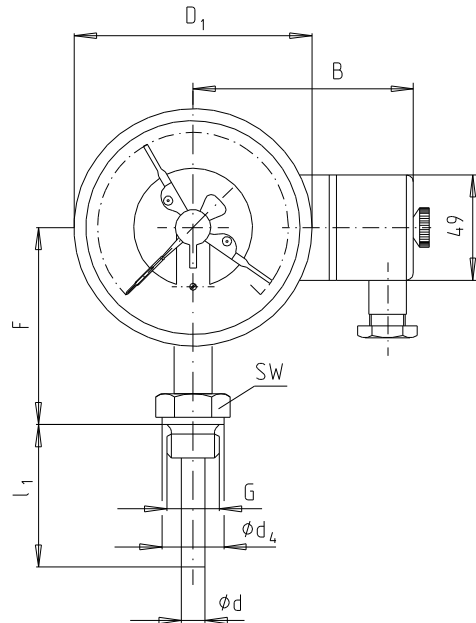

Dimensions: Model TM830/TM860

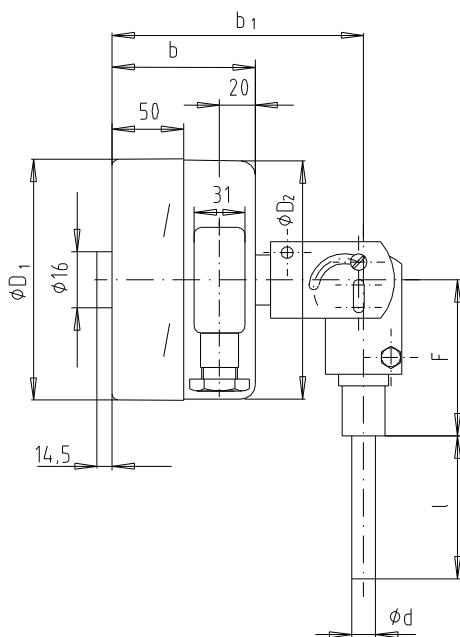

Connection	Dimensions (mm)						
	D (NG)	D ₁	D ₂	B	b	b ₁	F
Back mount	100	101	99	94	88	121	---
	160	161	159	124	100	133	---
Lower mount	100	101	99	94	88	---	83 ¹⁾
	160	161	159	124	100	---	113 ¹⁾
Turnable/ rotateable	100	101	99	94	88	131	68 ¹⁾
	160	161	159	124	100	143	68 ¹⁾

¹⁾ for measuring ranges ≥ 400 °C: +40 mm

Further dimensions see table Design of connection on page 3

Dimensions: Model TM870

Panel mounting flange

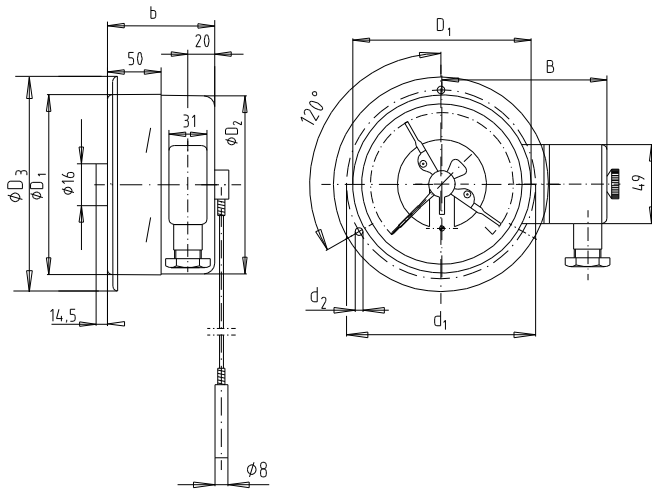

Surface mounting flange

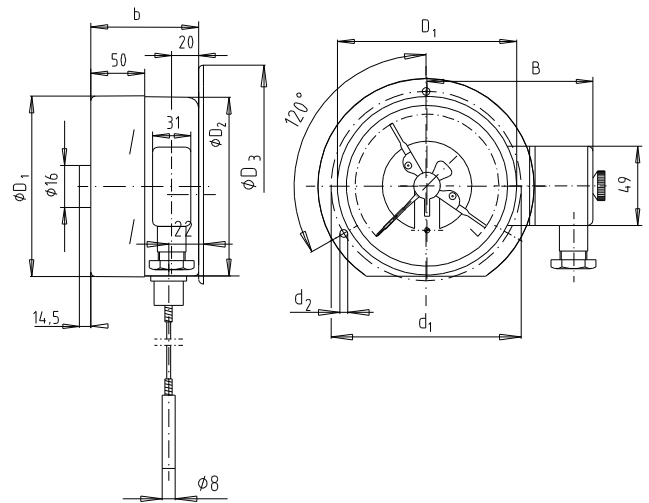

Surface mounting bracket

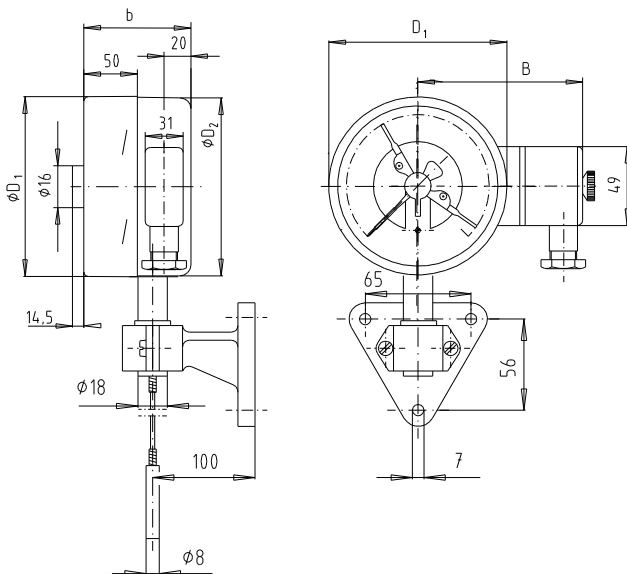

Case mounting	Dimensions (mm)							
	D (NG)	D ₁	D ₂	D ₃	d ₁	d ₂	B	b
Panel mounting flange	100	101	99	132	116	4,8	94	88
	160	161	159	196	178	5,5	124	100
Surface mounting flange	100	101	99	132	116	4,8	94	88
	160	161	159	196	178	5,5	124	100
Surface mounting bracket	100	101	99	---	---	---	94	88
	160	161	159	---	---	---	124	100

Order details:

nominal size, measuring principle, measuring range, process connection, contacts: type, numbers, function; stem length, stem diameter, capillary length, thread

Subject to technical modifications